

TECHNICAL DATA SHEET V/P200

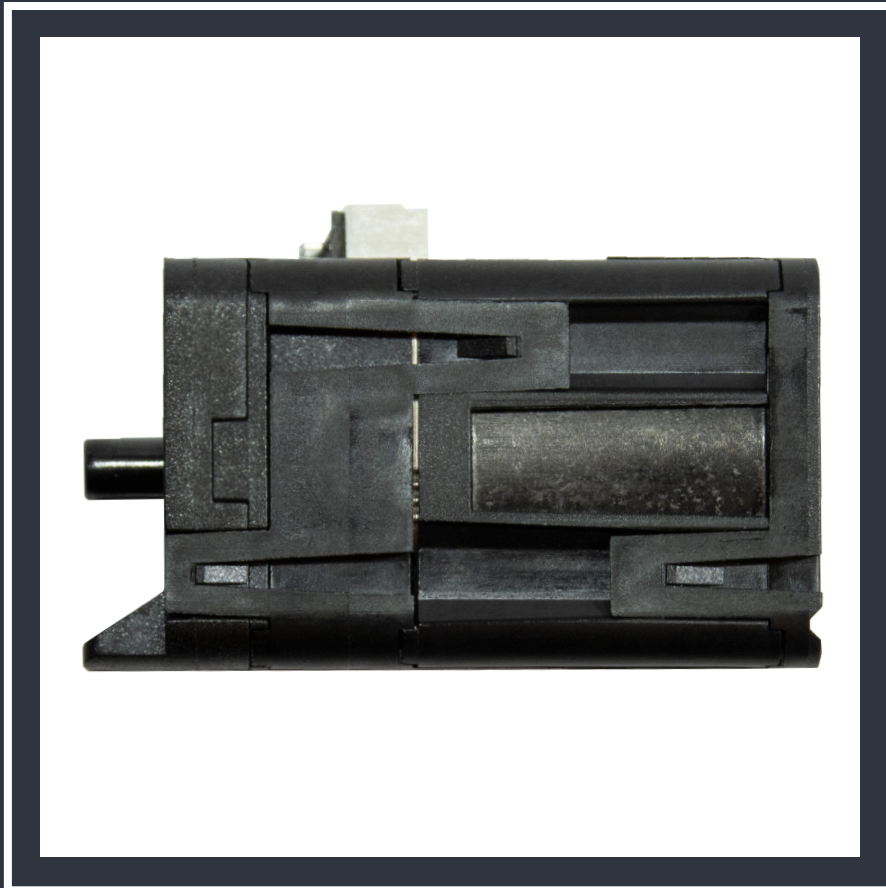

Analog Black Edition Gas Pumps

2. General Information
3. General Flow Performance
4. Standard Models
5. Electronic Interface
8. Performance Charts
9. Drawings

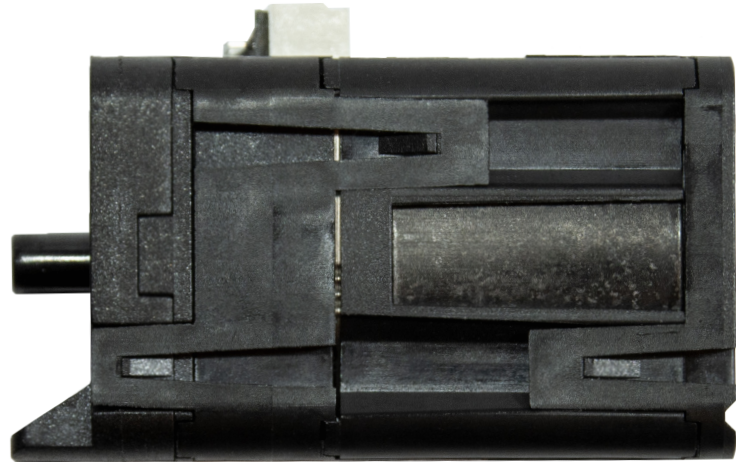

BLACK EDITION MICRO PUMPS FROM XAVITECH

Xavitech's Black edition is our pump model with the most functionality and flexibility. Our goal is for you to be able to use this micro pump in your new system or as a drop-in replacement in your existing system easily and conveniently.

FEATURES

- Small footprint
- Easy to install with vibration absorbing pump mountings
- Customized calibrations
- Silent mode
- Blockage detection
- Can operate on battery
- Choose the operating voltage between 3.3VDC – 24VDC

SELECT THE LIFETIME

At Xavitech you can choose between 3 different lifetimes:

Choose between:

- | | |
|---------------|-------------------|
| 10 000 hours | (1-year warranty) |
| 20 000 hours | (2-year warranty) |
| +35 000 hours | (3-year warranty) |

ANALOG OR INTELLIGENT?

The Black edition pumps are divided into two categories; The Analog edition and the Intelligent edition. The analog edition comes with a 3-cable connection and allows for analog control and can be used with our AFC for easy experimenting.

The Intelligent edition has serial control and can be programmed by you. Use one of our adapters (App, computer adapter or FCU) for easy experimenting or use Arduino for example. See separate datasheet for more information.

All Black edition pumps can be custom calibrated, to a set flow for example, by us at the factory.

Examples of customized firmware:

- Set the flowrate to a specific value
- Silent mode
- Programmable Maximum Pressure
- Keep performance on battery operation

Contact us if you are wondering how the Black edition pump can best serve your system.

V/P200 BLACK ANALOG PUMP

General Flow Performance

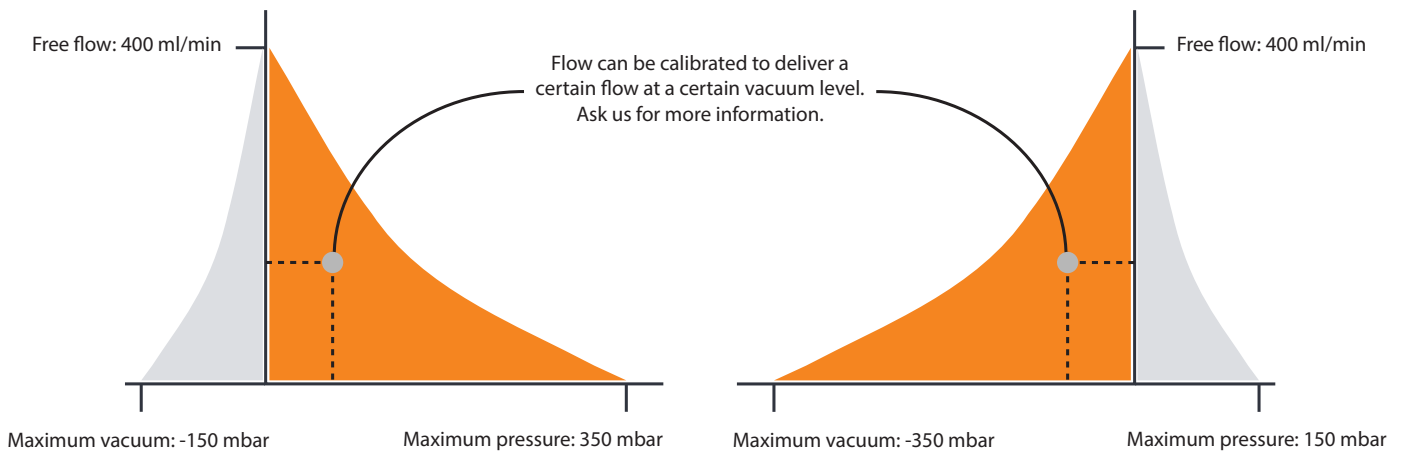

IMPORTANT NOTES

- Pump Flow: Flow is one-directional, it cannot be reversed
- Filters: To ensure lifetime, air filters should be used to prevent contaminations like dust to enter the pump
- Capacitor: Missing VCC capacitor can damage the pump on 24-volt variants. See the electronic interface section for capacitor suggestions
- Connections: Incorrect lead connection can damage the pump

V/P200 BLACK ANALOG PUMP

Standard Models

STANDARD MODELS (PART NUMBER)

Xavitech provides several pre-calibrated standard models. For these models, the voltage and the maximum flow is calibrated to standard values. When buying a standard pump, you still have a few choices you can make. Choose voltage, connection and lifetime. And if you're pumping aggressive gases you can choose Viton for wetted rubber parts. The chart below lists the standard pumps models that Xavitech can offer. But custom calibration is also an option, please contact Xavitech for more information.

PART NUMBER	VOLTAGE (V DC)	FREE FLOW (ml/min)	MAXIMUM PRESSURE/ MAXIMUM VACUUM (mbar)	CONNECTION INTERFACE	ANALOG FLOW CONTROL	SERIAL INTERFACE (RS-232)	LIFE TIME (Hours)
P200-B3C5V	5	400	300	3 Wires	✓	✗	10 000 - +35 000
P200-B3C12V	12	400	350	3 Wires	✓	✗	10 000 - +35 000
P200-B3C24V	24	400	350	3 Wires	✓	✗	10 000 - +35 000
V200-B3C5V	5	400	-300	3 Wires	✓	✗	10 000 - +35 000
V200-B3C12V	12	400	-350	3 Wires	✓	✗	10 000 - +35 000
V200-B3C24V	24	400	-350	3 Wires	✓	✗	10 000 - +35 000

CONTROL

Read more about how to control the pump flow with either analog signal or with serial interface and how to choose your custom calibration point in the respective sections down below.

V/P200 BLACK ANALOG PUMP

Electronic Interface

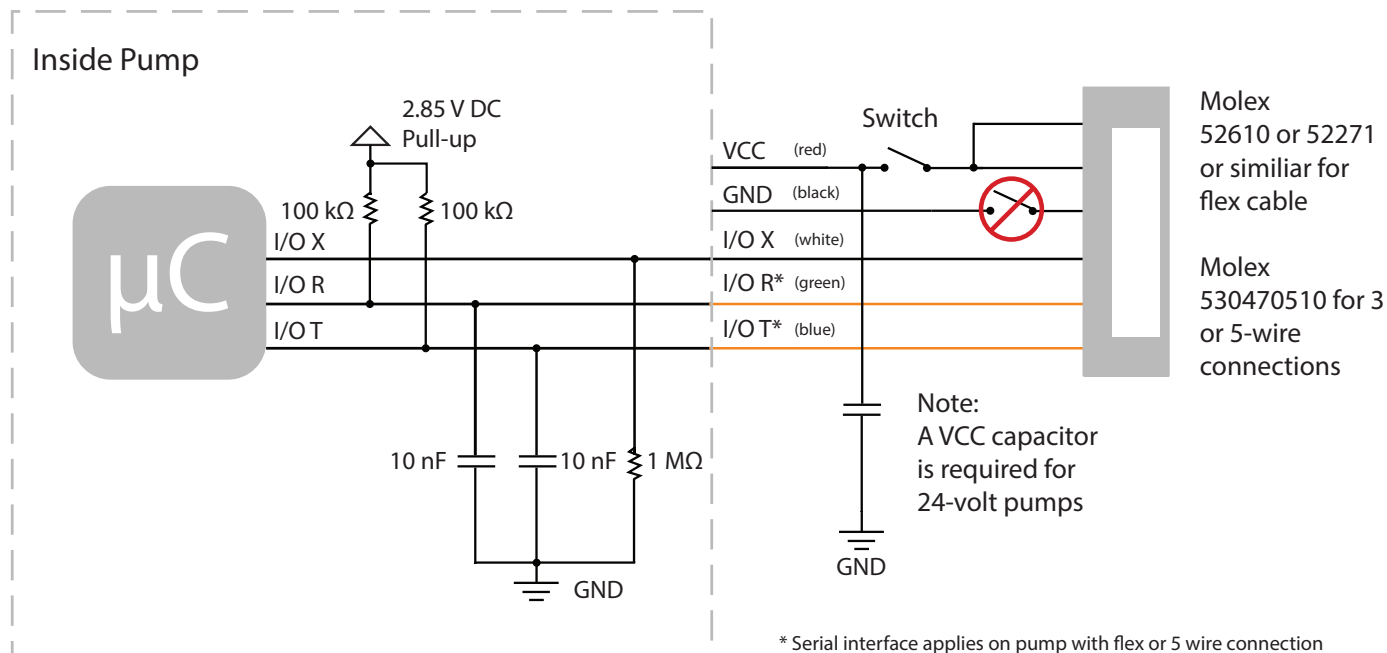

Figure 2: Electronic interface

INTERFACE DESCRIPTION

VCC (SUPPLY VOLTAGE)

Each pump is calibrated to run at an input voltage in the range of 3.2 to 24 V DC. The supply voltage can be customized for each customer's need.

Maximum input voltage: Calibrated voltage + 0.5 V DC. The pump can be damaged otherwise.

Minimum input voltage: 3.2 V DC. However, the pump performance is reduced if the voltage is set lower than calibrated value. Xavitech recommends to always run the pump at the calibrated voltage.

Figure 3 shows in terms of current consumption a typical pump stroke cycle. Since the motor of Xavitech pumps is based on an electromagnet, a negative current will occur when the electromagnet is turned off. It is because of this current a capacitor is needed between VCC and GND.

If your system cannot handle this spike generated by the electromagnet, a Schottky diode (flyback diode) can be used instead of the capacitor.

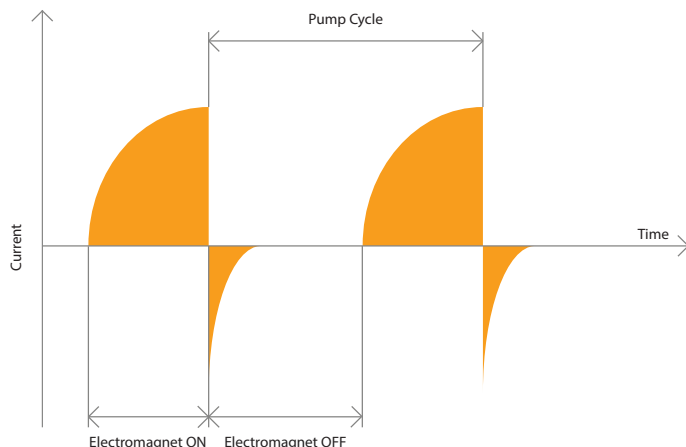

Figure 3: Typical pump cycle

V/P200 BLACK ANALOG PUMP

Electronic Interface

I/O X

This is a general I/O connected to an A/D converter of the microcontroller inside the pump.

The default functionality is frequency control:

- 0 – 0.05 V DC: Maximum frequency of the pump
- 0.06 – 2.75 V DC: Frequency control of the pump
- 2.75 – 2.85 V DC: Pump stops
- Max input voltage: 3.3 V DC (the pump can be damaged if exceeded)

Note that the frequency adjustment can only lower the frequency from the factory default frequency. Normally a pump is calibrated to have its maximum frequency (maximum flow) set as default at factory.

The use of I/O X can be customized for each customer's need. I/O X can be an analog- or digital input or output. Please contact an Xavitech representative for more information.

SWITCH THE PUMP ON AND OFF

The Analog Xavitech pump can be turned on and off in two different ways:

1) Via the I/O X connector: Apply a voltage of at least 2.75 V DC (max 3.3 V DC) and the pump will stop. The pump will start within a few milliseconds (depending on what frequency the pump is calibrated in default) when a voltage lower than 2.75 V DC is applied. However, note that the internal microcontroller will still run so the pump will consume <10 mA.

2) Switch power on and off: The power must be switched on the VCC line (see Figure 2). The pump will be damaged if the switch is placed on the GND line. The capacitor has to be placed between VCC and GND on the pump side of the switch. This is because of the back EMF current that the electromagnet generates. Using this method of turning the pump off, it will not consume any power, but the microcontroller will perform the start-up procedure which takes up to 3 s (depending on default pump frequency) when the power is turned on. During this time, the pump adjusts the stroke length to reach its calibrated length. The regulation adjusts the stroke length for every pump stroke thus it depends on the pump frequency.

V/P200 BLACK ANALOG PUMP

Electronic Interface

CAPACITOR SPECIFICATIONS

Xavitech recommends using a capacitor parallel to the power supply (see Figure 2) to reduce the power spikes generated by the electromagnetic motor. For 24-volt pumps, a VCC capacitor is required to not damage the pump. See the recommended capacitors sizes below.

Pump	Recommended Capacitor
V200-5V	470 μ F, 10 V
V200-12V	470 μ F, 16 V
V200-24V	470 μ F, 35 V
P200-5V	470 μ F, 10 V
P200-12V	470 μ F, 16 V
P200-24V	470 μ F, 35 V

V/P200 BLACK ANALOG PUMP

Performance Charts

PERFORMANCE CHARTS

The charts show typical performance and are provided as a reference. Exact performance will differ between pump individuals.

Flow Vs. Pressure (P200 @ 5 V DC)

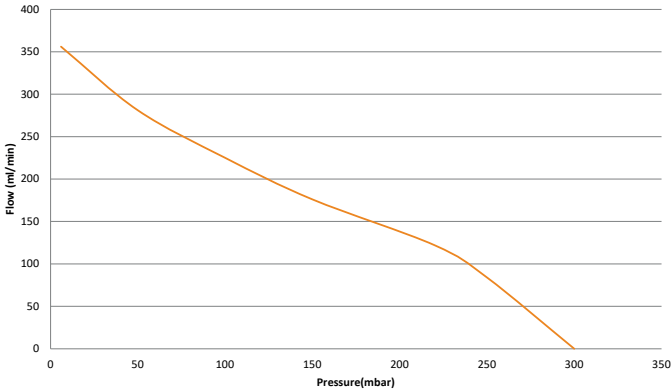

Flow Vs. Pressure (P200 @ 12 V DC)

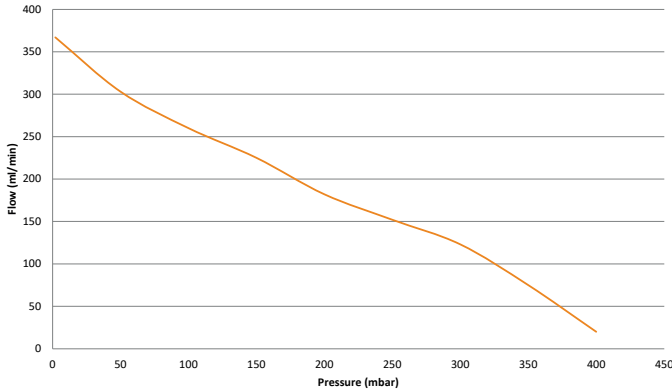

Flow Vs. Vacuum (V200 @ 12 V DC)

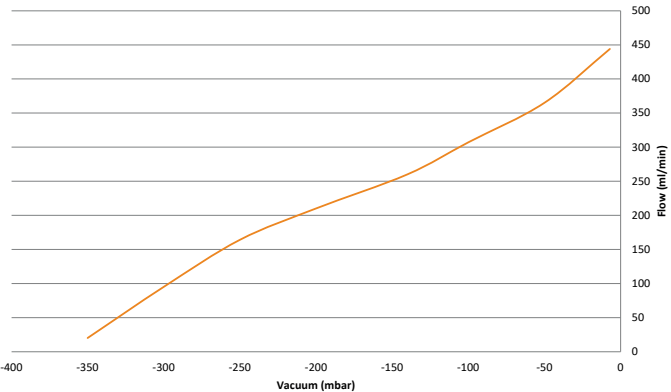

Flow Vs. Vacuum (V200 @ 5 V DC)

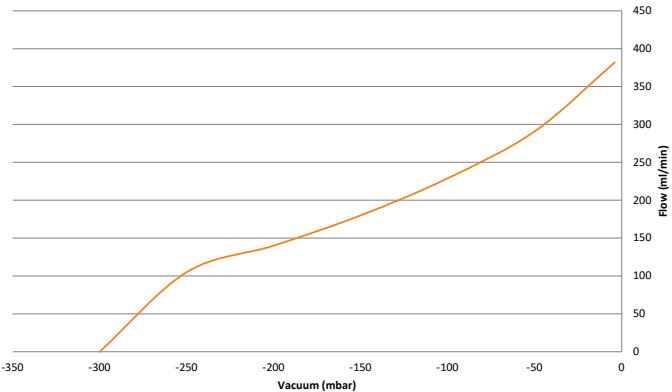

V/P200 BLACK ANALOG PUMP

Drawings

BLACK EDITION V200 AND P200 WITH 3 OR 5 WIRE CONNECTION

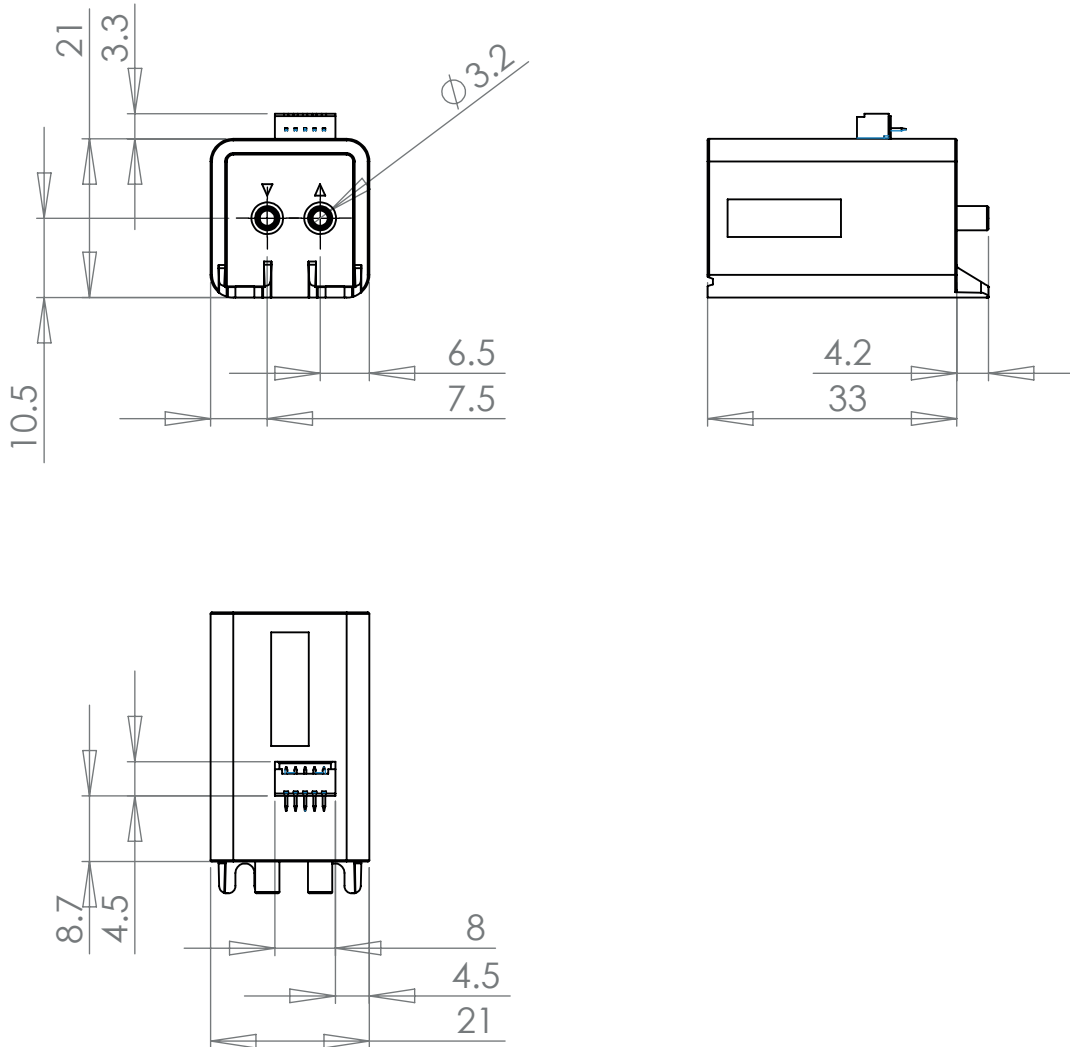

PUMP MODEL	V200 AND P200 BLACK EDITION
Connection	3 wires with connector
Drawing Scale	1:1
Dimension Tolerance	± 0.2 mm
Pump Weight	40 ± 2 g
Recommended Connectors	MOLEX 530470510 (Picoblade)
Recommended Tube Inner Diameter	1.6 - 2.8 mm (Material dependent)

This information is accurate and reliable. However, specifications mentioned in this publication are subject to change without notice. This publication supersedes and replaces all information previously supplied. Xavitech products are not authorized for use as critical components in life support devices or systems without express written approval of Xavitech.

© 2023 Xavitech - All Rights Reserved